

OPTIMUM



MARINE

AUTOMATIC RELEASE HOOK FOR DAVIT LAUNCHED LIFE RAFTS 21-25KN

Index:

1. The Optimum Marine 21-25kN Release hook.	Page 2.
2. Safety instruction.	Page 2.
3. Installation and maintenance record	Page 3.
4. Technical specifications.	Page 4.
5. Installation & operating guide.	Page 5.
6. Instructions for maintenance.	Page 6.
7. Drawing and spare part list.	Page 7.

1. The Optimum Marine 21-25kN release hook.

The 21-25kN release hook meets the high SOLAS standards for release hooks, as described in the MSC.81(70) and applicable LSA code and is dimensioned to suspend davit launched life rafts with a davit load not exceeding 2.500 kg.

For your information:

- Use non-rotating wire rope.
- Use a painter line where possible.
- Use a shackle $\varnothing 19\text{mm}$ up to $\varnothing 27\text{mm}$.

During installation of the hook, only the top shaft should be disassembled. Full disassembly of the hook can cause un-repairable damage to the system and dangerous situations which can lead to injuries or death of personnel.

2. Safety instructions.

For your safety, please carefully read the instruction before using the release hook to prevent improper operation and to ensure your personal safety.

For a safe operation, all operators and persons involved in installation, maintenance and operation of the 21-25kN release hook must familiarize themselves with this instruction manual to ensure they are familiar with the system functions and know how to use them. The hook should only be operated by persons who understand the functionalities and routines. We advise to make this manual easily available on board for personnel working with the 21-25kN release hook.

- Make sure that the operator understands the functionality of this release system completely to ensure it can be operated safely.
- Always check that the hook is in good shape before commencing a drill.
- If any hazardous condition is found, this needs to be reported immediately and the hook must be put out of operation.
- For maintenance and overhaul only, original spare parts should be used.
- For maintenance and overhaul always use appropriate tools.

3. Installation and maintenance record.

Hook type:.....

Serial number:.....

Date of installation:.....(after this date the 5 year lifecycle starts)

Monthly inspections year 1.	Date	Approve	Date	Approve	Date	Approve
Monthly inspections year 2.						
Monthly inspections year 3.						
Monthly inspections year 4.						
Monthly inspections year 5.						

The hook now needs to be replaced or overhauled by an authorized provider, please contact us at info@optimum-marine.eu for authorized providers.

4. Technical specifications.

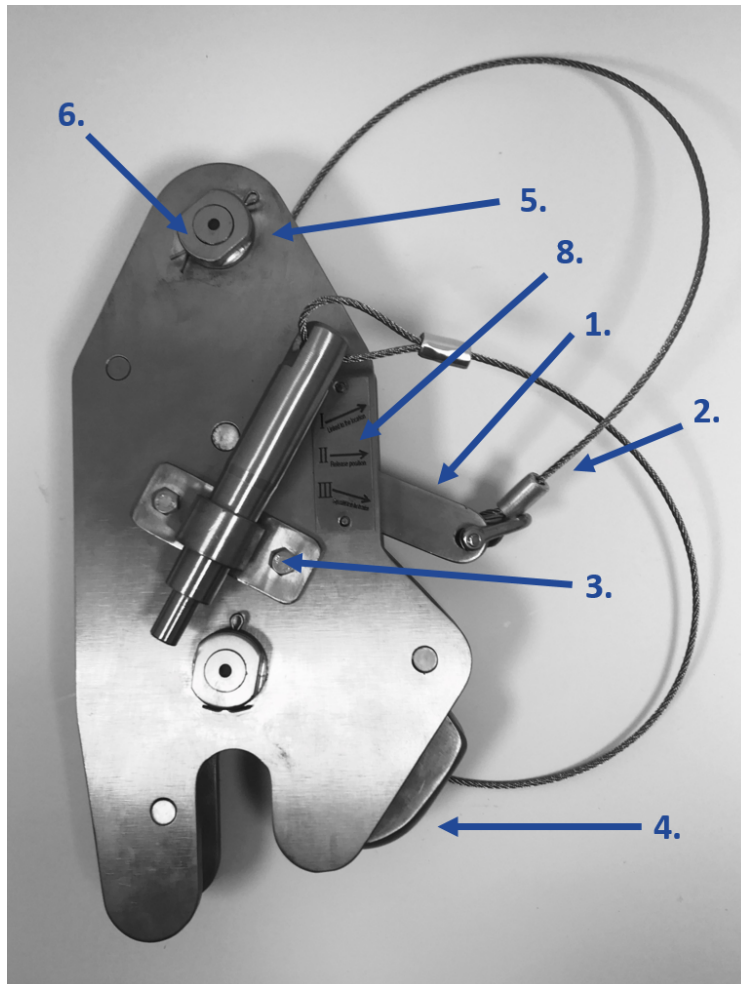

1	Actuating lever
2	Cord with latch
3	Latch holder
4	Hook with latch hole
5	Distance bush and shaft
6	Nut
7	Type plate on the other side
8	Position plate

The 21-25kN automatic release hook is intended to be used on life rafts. Manufactured in seawater resistant stainless steel. The rope handle activates the release. The Safe Working Load of the 21-25kN is 2500kg.

5. Installation and operating guide.

Installation.

Installation of the hook is easy, disassemble the top shaft by removing the cotter pin and unscrewing the nut (position 6 and 5). Place the spliced eye or corresponding wire rope fall over the distance bush. Place the distance bush between the two side plates and place the shaft. Then make sure the shaft is fastened tightly and the cotter pin is put back in place.

Operation.

The 21-25kN should be set to automatic, by pulling the cord (the latch can be used as handle) before the raft gets lifted. When the rafts become waterborne the hook opens automatically.

Please note, the hook requires a minimum load of 150 kg, before the automatic release function works. When there is not enough (less than 150 kg) load on the hook, pulling the cord will open the hook immediately.

All hook handling can be done by one person. The hook is designed to be opened manually if a towing strain prevents automatic opening of the hook, just pull the cord on more time and the hook will open under load.

Connecting the link into the hook.

Before we place the suspension link into the hook, we must bring the actuation lever in the lowest position (position 3.), by pulling the cord. Place the latch in the hook, as well as the link. Now close the hook with the latch, the actuating lever should jump to its highest position (position 3.).

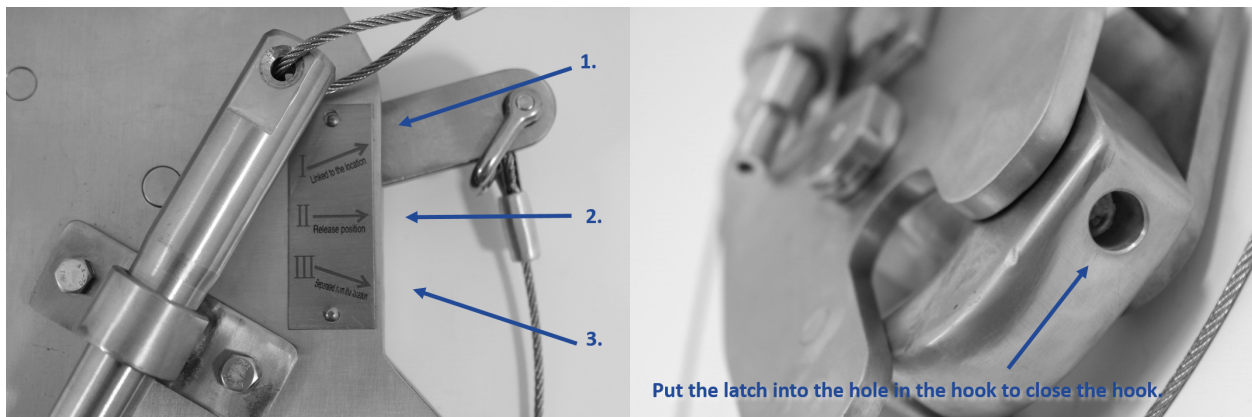

We recommend, to pull the handle and cord during lowering, just before the raft is waterborne. When waterborne, the hook will automatically open and the raft can be maneuvered away from the vessel. If a towing strain, or waves keep a load on the hook, the automatic function will not release the raft, then pull the handle/cord once more to release the hook.

6. Instructions for maintenance.

This release hook requires frequent maintenance to ensure good working order in all conditions.

Preventive maintenance can be done by any of the crew members and consists of:

- Keeping the hook clean, by cleaning with regular soap and water.
- Keeping all moving parts lubricated.
- Check for, and adjustment of, wear and tear parts.

Always check the bow-shackle before use and make sure the tightening bolt are fit tightly. If the release hook will not be used for a longer period, please store it in the released position.

Maintenance regulations.

Below points must be followed to ensure the hook and its operation is in compliance with the regulations:

- Certificates, inspection and maintenance records must be kept and be available on-board.
- Replacement of parts must be carried out in accordance with the manufacturer's requirements and standards.
- Maintenance time schedule as per below must be followed.
- The hook should only be disassemble/ assembled by an authorized person.

	Weekly	Monthly	5-yearly
Clean and visual inspection, check for defaults.	x		
Lubricate moving parts.		x	
Check connection of wire rope to the hook.		x	
Check release cords (replace with original spare part, if damaged).		x	
Check automatic release function.		x	
Replace hook			x

7. Drawing and spare part list.

Only use original spare parts when maintaining the 21-25kN release hook. All spare parts are available from Optimum Marine - info@optimum-marine.eu

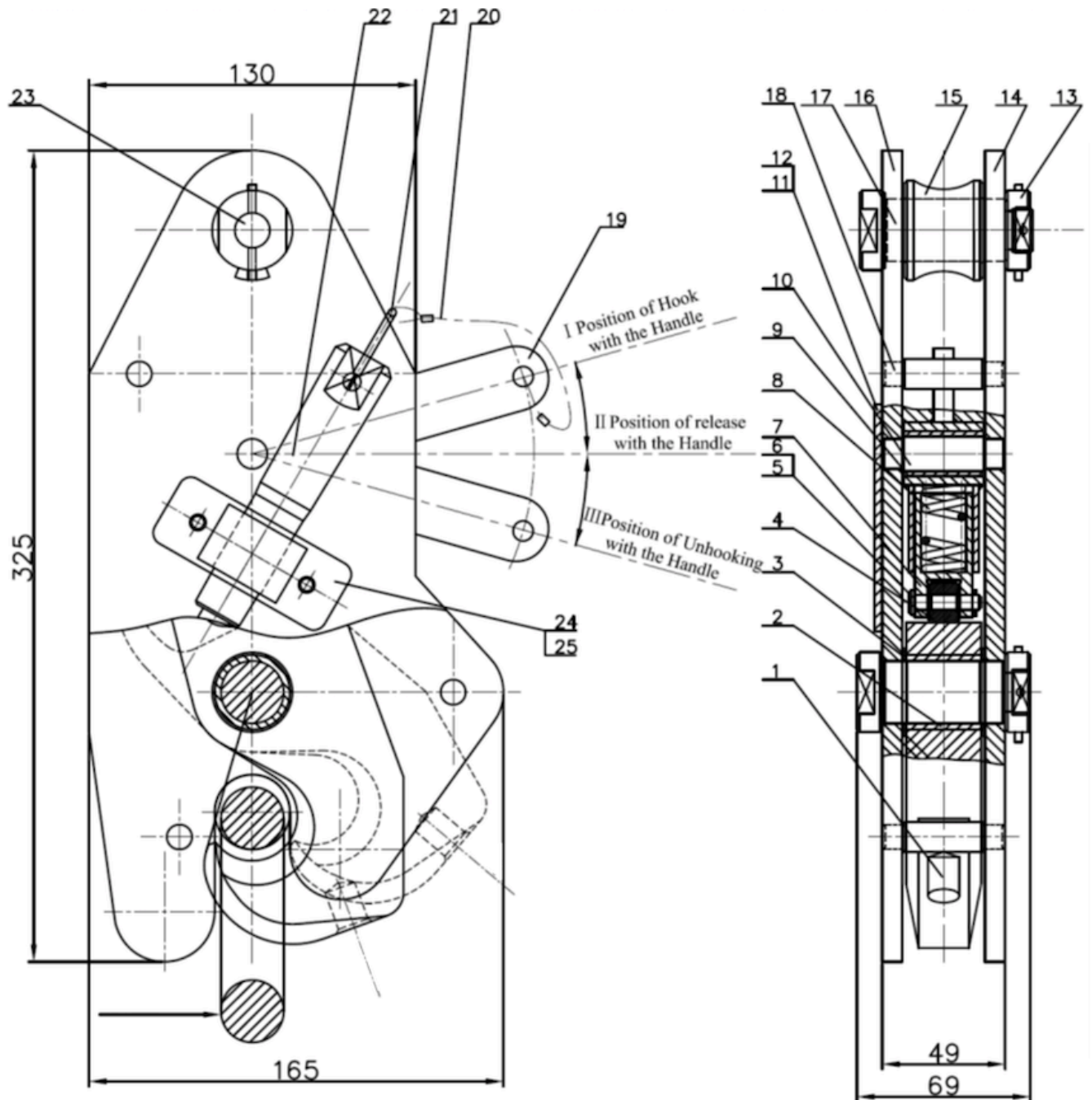

25	M6*12(GB30-76)	BOLT	2	1Cr18Ni9Ti
24	250NY-19	LATCH SEAT	1	1Cr18Ni9Ti
23	Ø3*45(GB91-76)	COTTER	2	1Cr18Ni9Ti
22	250NY-18	LATCH	1	1Cr18Ni9Ti
21	0.2/200	SHACKLE	1	1Cr18Ni9Ti
20	250NY-17	HANDLE WIRE	1	1Cr18Ni9Ti
19	250NY-16	SPRING SEAT	1	1Cr18Ni9Ti
18	250NY-15	LOCATION PINTLE	4	1Cr18Ni9Ti
17	250NY-14	PINTLE	2	1Cr18Ni9Ti
16	250NY-13	LEFT SIDE PLATE	1	1Cr18Ni9Ti
15	250NY-12	ROLLER	1	1Cr18Ni9Ti
14	250NY-11	RIGHT SIDE PLATE	1	1Cr18Ni9Ti
13	250NY-10	NUT	2	1Cr18Ni9Ti
12	M5*8(GB67-76)	SCREW M5*8	4	1Cr18Ni9Ti
11		INDEX PLATE	1	1Cr18Ni9Ti
10	250NY-09	PINTLE	1	1Cr18Ni9Ti
9	250NY-08	STEEVE	1	H62
8	250NY-07	SPRING	1	1Cr18Ni9Ti
7	250NY-06	SPRING SEAT	1	1Cr18Ni9Ti
6	250NY-05	PULLEY PINTLE	1	1Cr18Ni9Ti
5	Ø1.8*12(GB91-76)	COTTER	1	1Cr18Ni9Ti
4	250NY-04	PULLEY	1	1Cr18Ni9Ti
3	250NY-03	GASKER	2	H62
2	250NY-02	CU STEEVE	1	H62
1	250NY-01	HOOK	1	1Cr18Ni9Ti
NO	ITEM	NAME	QTY.	MATERIAL